



Full citation: credofilm, ed. "*Under Control* Press Kit." Berlin: credofilm, 2011.  
<http://www.environmentandsociety.org/node/3937>.

First published: [http://www.credofilm.de/english/filme/unter\\_kontrolle.html](http://www.credofilm.de/english/filme/unter_kontrolle.html).

Rights: All rights reserved. © 2011 credofilm  
© all images Stefanescu/Sattel/Credofilm  
Made available on the Environment & Society Portal for nonprofit educational purposes only.

# UNDER CONTROL

AN ARCHAEOLOGY OF NUCLEAR ENERGY  
A FILM BY VOLKER SATTEL



Documentary | GER 2011 | 98 min | 35 mm Cinemascope | English subtitles | "highly recommended" by the FBW

## CANNES MARKET SCREENINGS:

Saturday, 14 May 2011 - Olympia 4 at 6 pm

Tuesday, 17 May 2011 - Riviera 3 at 4 pm



## **Under Control**

An archaeology of nuclear energy

The film starts with a promise. Something glows, vibrates for a moment, builds structures of beauty – a “light” that our eye cannot see, the wild heart of a technology that has always had the notion of “control” at its core.

If one follows Volker Sattel, taking in the parade in gliding tracking shots, scanning the objects, buildings and equipment that fall under the term “nuclear energy,” a utopian project is revealed, right here in our midst, that requires no words of explanation.

„Under Control“ offers the rare opportunity to marvel at this unfinished monument to a glorious future, as it has not lost its potential to fascinate, despite cracks and dangerous contradictions. The film also reveals the extent of the attempts to reconcile this kind of science fiction – the “peaceful” use of nuclear energy – with reality.

It is a world explained in small doses, providing insight into the secret life behind the walls of German nuclear plants. We see glisteningly bright control rooms, decontamination locks, smoke screen devices, enter the depths of the mineral deposits to experience the power of superhuman rationality that is supposed to keep the power of the particles under control.

Not coincidentally the architecture and the props are reminiscent of an earth-bound space flight. In this world, too, mistakes are not permitted. But since it’s difficult enough to warm to the notion of a journey over decades, the half-life periods of radiant substances are beyond the scope of our imagination.

In the end we are left with a sense of futility. It’s almost as if we have disappointed nuclear power, and not the other way around. The miracle of this technology is patiently waiting for a new human being that is more rational – and not afraid of eternity.

**Synopsis:** The documentary “Under Control” unfolds a panorama of atomic energy in Germany. Its broad perspective reveals the real challenges and enormous efforts that nuclear power demands from humankind. The control over the nuclear fission process is not depicted chronologically but rather as a prism of places and sites that not only refracts the stations of the German atomic age but also reflects beyond the current situation. The examination of a technology once synonymous with progress also touches on elements of the history of civilization.

**TECHNICAL DETAILS**

Running Time	98 min
Format	35 mm, Cinemascope, 1:2,40, 25fps, Color
Sound	Dolby Digital
Language	German, English
Subtitles	English, German
English Title	Under Control
Year of Production	2011
Country of Production	Germany
Genre	Documentary

**CREW**

Script, Research, Director	Volker Sattel
Together with	Stefan Stefanescu
DOP	Volker Sattel
Camera assistant	Thilo Schmidt
Sound	Nikolaus Woernle, Filipp Forberg
Sound Design	Tim Elzer, Nikolaus Woernle
Mix	Ansgar Frerich
Editor	Stefan Krumbiegel, Volker Sattel
Dramaturgy	Stefanie Gaus
Line producer	Dorothea Seeger
Assitant of Production	Katharina Bergfeld
Producer	Susann Schimk, Jörg Trentmann
Comissioning Editors	Jutta Krug (WDR), Sabine Rollberg (ARTE)

© 2011 credofilm in cooperation with WDR and ARTE. Funded by Kuratorium junger deutscher Film | Gerd Ruge Award | Filmstiftung NRW and the German Film Fund





**VOLKER SATTEL**, born 1970 in Speyer am Rhein, studied direction and cinematography at the Filmakademie Baden-Württemberg in the documentary department. Since then he realized projects as DOP and director, especially in the documentary genre and the field of experimental feature film in cooperation with Mario Mentrup. Since 1999 he worked as a private lecturer at the KHM Köln and the HFF "Konrad Wolf", Potsdam. In 2008 he was awarded the Gerd Ruge Projektstipendium for "Under Control".

Filmography (Selection):

**UNDER CONTROL** [Unter Kontrolle] Documentary | 98 min | 2011 | 35mm |  
Gerd Ruge Stipendiums from the Filmstiftung NRW | Berlinale Forum 2011, Bafici,  
Dok.fest München, Jeonju IFF

**LEGENDEN** Experimental film | 30 min | 2008 | 16mm | directed by A. Dubois  
2. Award Kurzfilmtage Oberhausen 2010, NRW Competition

**RODAKIS** Documentary | 12 min | 2007 | 35mm | directed by O. Nicolai  
58.Internationale Filmfestspiele Berlin, Forum expanded, Athens Biennial, Toronto 2008,  
Vancouver 2008

**ICH BEGEHRE** Feature Film | 76 min | 2007 | HDV | directed together with M. Mentrup

**THEY COME AT NIGHT** [Sie kommen nachts] Documentary | 29 min | 2006 | DigiBeta  
Transmediale Berlin 2008, Documenta Madrid, Portobello Film Festival London, Int.  
Videofestival Bochum, East Silver doc, Sheffield doc festival

**LAUFHAUS** Documentary | 30 min | 2006 | 16mm | directed by S.Gaus  
Duisburger Filmwoche, Kurzfilmtage Oberhausen, Biennale de l'image Geneva,  
Documenta Madrid, Festival des Deutschen Films Mainz, Portobello Filmfestival London,  
Pornfilmfestival Berlin, Fresh Film Festival, Karlovy Vary

**AFTER EFFECT** Feature Film | 90 min | 2005 | DV | directed by S. Geene  
Filmfestival Oldenburg 2007

**CITY OF LIGHTS** [Stadt des Lichts] Feature Film | 60 min | Video | 2005 | directed  
together with M. Mentrup  
Pesaro Int. Filmfestival, Italien 2008

**ENTERPRISE PARADISE** [Unternehmen Paradies] Documentary | 59 min | Super16 |  
2002 Cinema start and DVD Release at 24. 03. 05, First in TV at ARTE, 13.11.2004, 53.  
Berlin International Film Festival, Perspektive Deutsches Kino; European Media Arts  
Festival Osnabrück; Goethe-Institute New York and London; 26.Duisburger Filmweek;  
etc.. Awards: Sehsüchte 2003: „best editor und best photographie“, Videoex 2003  
Zürich: 2. Award for „International Competition“

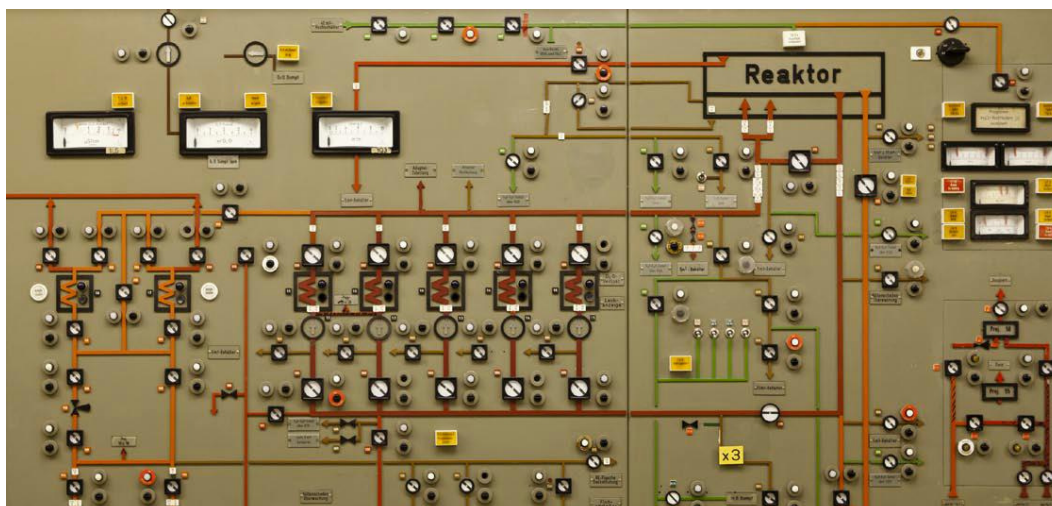

Director's Note

### **An Aged Utopia**

What I had in mind was a film that opens up a new view on the subject of nuclear power – away from the reflexes mediated by media and ideology. I was less interested in the issue of nuclear energy in terms of individual aspects, but much more in a perspective that opens up a panorama of the nuclear establishment.

Together with Stefan Stefanescu, with whom I worked out the idea of the movie, I took a research trip to the places in Germany and Austria that can be gathered up under the term “atomic energy”: nuclear power plants in operation and shut down, storages of radioactive waste, control agencies, research and training facilities. After some preliminary discussions, we had access to the world of these rigorously shielded systems. An equally fascinating and oppressive major technology was revealed to us, with all its former utopia and the legacy we have to deal with in the present.

In filmmaking, I am interested in the point of view. Cinema gives the view a form, it creates a space in which thoughts can emerge and that provides an insight into life. For my cinematic approach it is crucial that I can create my own point of view. I observe places and study what happens. I think carefully consider the camera position what I want to show.

The location “nuclear facility” implies that every interview and every camera take had to be agreed with the company’s management. Thus, it was part of the cinematic approach to position myself within the representation of the power plant owners.

We often shot the interviews from a distant side-face perspective to expand the matter of meaning with the perception of how things have been said. I worked with the given situation. Instead of a commentary, I arrange my view in the framework of the image and in the editing in a fictionalized structure. I rely on cinematic fields of vision, in which the audience can judge for themselves. My cinematic offer is a projection for the experience and imagination of the viewer. However, the viewer can stick to the obvious, the evidence of what he sees in the motion picture.

## **The containment of risk**

In the brightly lit command centers of the nuclear reactors, the trust in the infallibility of technology of the operators seems undiminished. All conceivable scenarios have been thought through and simulated. However, the fission process in the core of the reactor remains invisible to the team in the control room. They only can measure what is happening inside the reactor. They completely depend on the instruments and the displays in the control center. The “machine” has control over the personnel that is supposed to control the technology.

The film displays engineers, physicists, chemists and computer scientists. Some of the men have been working for more than 30 years in the power stations; others were previously employed in the mining industry or the military. The camera observes how they calmly do their job that has lost much of its reputation – a job that prepares problems and headaches with its historically anticipated end. Nevertheless, it seems that the staff feels highly familiar with the monstrous technology and is closely connected with nuclear energy. They describe the technology as something good-natured. But by their efforts of denying almost every problem of nuclear energy, uncertainty is noticeable.

“Under control” unfolds a panorama of atomic energy in Germany. Its broad perspective reveals the enormous challenges and tremendous efforts that this type of energy demands from humankind. In the control rooms, reactors and atomic waste storages the camera focuses on the efforts of the risk management. The relationship between man and machine is questioned in work environments usually hidden. With a view to the power plants, a history of civilization opens up like a piece of archeology. For me the film is an exploration of a technology that was once a synonym for progress. It was important for me to trace the hidden tragic. At the end of the movie there is no easy way out. The rooms, hallways and pressure locks in the nuclear power plant are deserted. The escaped spirit of the atom leaves its mark. What does it have in mind with us?

Volker Sattel



1/2

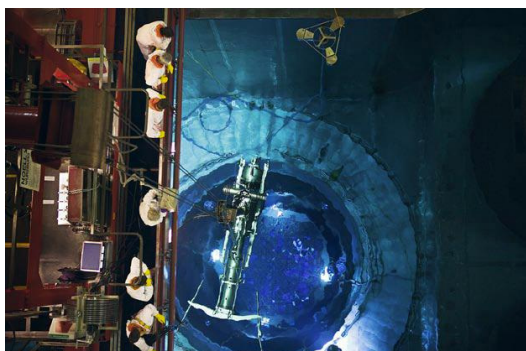

3/4

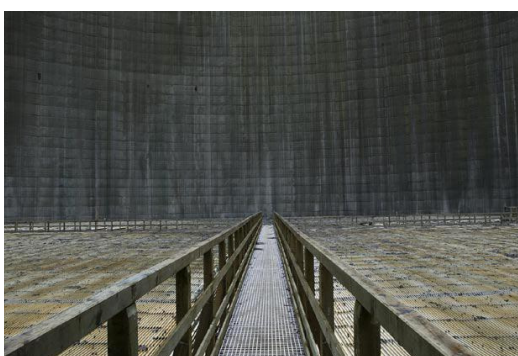

5/6

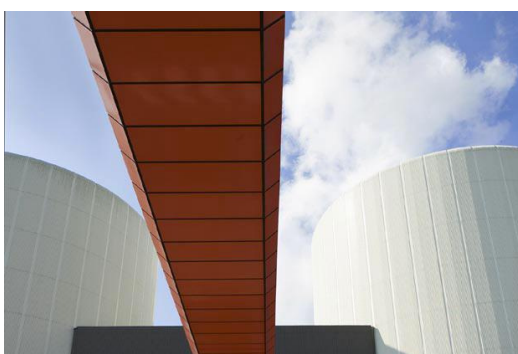

7



8/9

## Images

First Page:

- 1 Grohnde nuclear power plant, staircase
- 2 Revision workers during their lunch break underneath the gangway to the reactor blocks B and C in Gundremmingen, Bavaria
- 3 Institute for Transuranium Elements, Karlsruhe

Previous Page:

- 1 Control room Grohnde/Grafenrheinfeld im Simulatorzentrum Essen
- 2 Swing carousel in the cooling tower of the „Schneller Brüter“ (fast breeder reactor) in Kalkar, that never went into nuclear service. Germany' most expensive industrial ruin nowadays is an amusement park
- 3 Revision works at the open reactor core in the nuclear power plant of Gundremmingen, Bavaria
- 4 Decontamination works by sandblast in the „Zentrale aktive Werkstatt“ in the shut down atomic power plant in Greifswald
- 5 Elevator to the access to core reactor areas in the Gundremmingen power plant
- 6 Inside a cooling tower
- 7 Air-pressure control room of the shut down high temperature reactor in Hamm-Uentrop (North Rhine Westphalia), which is in „safe entombment“
- 8 Body counter for possible contamination by radioactive particles in the interim storage facility, Gundremmingen
- 9 Revision workers during their lunch break underneath the gangway to the reactor blocks B and C in Gundremmingen, Bavaria

**The image Data is available** on inquiry.  
© all images Stefanescu/Sattel/Credofilm

**Contact**

Production Company/  
World Distributor

credo:film GmbH  
Schiffbauerdamm 13  
D-10117 Berlin  
fon: +49.30.257 624 – 0  
fax: +49.30.257 624 – 22  
info@credofilm.de  
www.credofilm.de

Distributor Germany

farbfilm verleih GmbH  
Boxhagener Str. 106  
D-10245 Berlin  
fon. +49.30.29 77 29 44  
fax. +49.30.29 77 29 79  
info@farbfilm-verleih.de  
www.farbfilm-verleih.de